

MOOG

NE123-212-1 Series Dual DC Level Detector/Comparator

SPECIFICATIONS

Zero Adjustment:

Variable range set by fixed resistors

Time Constant:

Adjustable up to 10 seconds,
others possible

Gain Range:

Typically 50:1, other ranges possible

Input Range:

±10V

DPDT Relay Section:

- Jumper selectable
HI (+24V) or LOW (0VDC)
- May be used for latch/reset
operation, controlling an external
device, alarm, etc.

Temperature Range:

0°C to 50°C (32°F to 122°F)

Hysteresis:

±10 mV typical,
preset with fixed resistors

Power Consumption:

±50 mA @ ±15V
100 mA @ 24V with relay energized

Relay Contact Rating:

Consumption: 20.8 mA @ 24 VDC
Contact Rating: 2A @ 30VDC,
50 VAC

Contact Form: DPDT

Operating Time: 7 mSec (max)

Release Time: 3 mSec (max)

Bounce Time: Oper. 0.5 mSec/
Rel. 3.5mSec

Form Factor:

Eurocard 100 x 160 mm, 7 HP, 3 U

Weight:

0.40 lb (0.18 kg)

The Dual DC Level Detector/Comparator card is designed to provide a variable "window" width detection circuit on each channel. Front panel controls and test points provide independent setting of level and window width. Comparator status is indicated by front panel LED's. The output transistor may be used in an optional open collector mode, and the relay may be configured for latch/reset operation. Input signals are summed at the input amplifier, which has adjustable gain and zero. The summed signal feeds an up/down integrator that provides a variable time delay, used to eliminate the effects of transient over signal conditions. The comparator can also be configured as a single detection circuit.

The NE123-212-1 Dual DC Level Detector/Comparator Card is a forward compatible replacement for the E123-212-001.

FEATURES

- Dual channel window comparator
- Four inputs per channel
- Summing input amplifier
- Adjustable time delay
- Status indication with LED's
- Two sets of dry contacts per window comparator
- Transistor output option
- Preset hysteresis

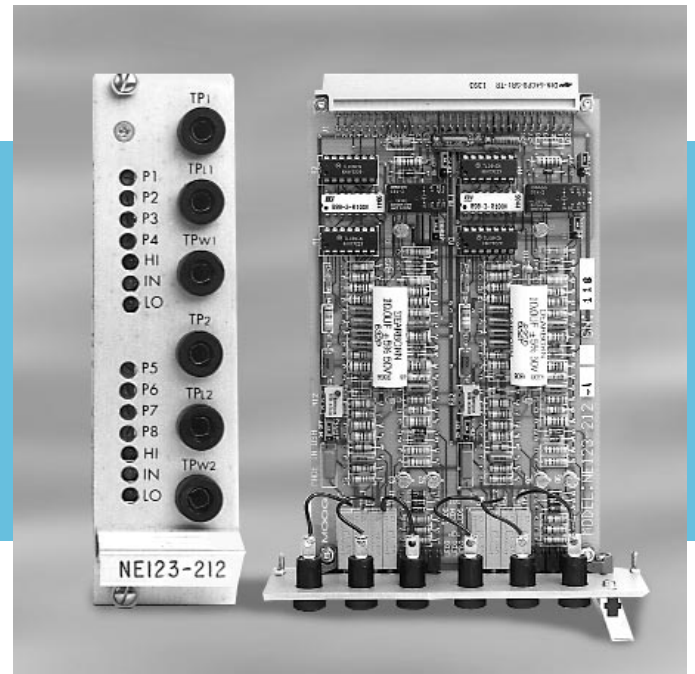

INSTALLATION AND SET-UP

Adjustment Procedure: Preliminary Test Set-up & Operational Verification

- All voltage readings are to be taken with respect to Pin-22 SIGNAL COMMON unless otherwise specified. All Set-up procedures will be referenced to Channel-1. Refer to schematic diagram for Channel-2 designations. Channel-1 & Channel-2 electronic functions are identical.
- Ensure "Jumpers" on PC Board are as follows:

CH1:

JMPR1	ON	Relay latch/reset Operation
JMPR2	ON	Output Transistor Open Collector Mode
JMPR3	OFF	Up/Down Integrator Time Delay

CH2:

JMPR4	ON	Relay latch/reset Operation
JMPR5	ON	Output Transistor Open Collector Mode
JMPR6	OFF	Up/Down Integrator Time Delay

- Ensure NE123-212 "Potentiometers" are pre-set as follows:

CH1 CH2

P1	P5	Full CCW	Gain Adjust
P2	P6	Full CCW	Time Adj (Integrator Time Delay)
P3	P7	Full CW	Level Adjust
P4	P8	Full CW	Window Adjust
R12	R62	Mid-Range	Zero Adjust (Offset or d-c Bias)

- Observe front panel LED comparator status indicator lights:

CH1:	HI LED	LED3	RED
	LO LED	LED2	RED
	IN LED	LED1	GREEN
CH2:	HI LED	LED6	RED
	LO LED	LED5	RED
	IN LED	LED4	GREEN

- Connect Jumper Wire across Pin-22 (Signal Common) and Pin-24 (Power Ground).
NOTE: Failure to connect both grounds together will result in incorrect Comparator circuit operation and false transitions.
- Check DC Offset Voltage at TP1. Ensure voltage is set for 0.00 ± 0.01 VDC. 'Fine tune' R12 if necessary to obtain 0.00 VDC at TP1.
- Determine desired Input Voltage Range to be monitored. Comparator max window range to be monitored is ± 10.0 VDC.
- Verify voltage reference points on front panel: Channel-1
TP1 Zero-1 Output Voltage Test Point
TPL1 Level-1 Reference level setting voltage
TPW1 Window-1 Upper/lower voltage limit setting
- Apply +15VDC to Pin-5 & -15VDC to Pin-9 outputs for Relay (RL1) contacts. Monitor Relay Contact output voltage at Pin-7.
- Apply $+1.00 \pm 0.05$ VDC to Pin-2 (Command or Error Monitoring Voltage Input). Verify -1.0 ± 0.05 VDC at TP1 on front panel.
- Verify 0.00 ± 0.01 VDC at TPL1 (Level Set) on front panel.
- Verify -2.0 ± 0.01 VDC at TPW1 (Window limit set) on front panel.
- Adjust input voltage to Pin-2 From +3 VDC to -3 VDC.
 - Adjust input voltage at Pin-2 for $\geq +2.1$ VDC.
The "HI LED" (Red) on front panel will be "illuminated".
Verify Relay Output Voltage at Pin-7 is -15.0 ± 0.1 VDC.
 - Adjust input voltage at PIN-2 for ≤ 2.1 VDC.
The "LO LED" (Red) on front panel will be "illuminated".
Verify Relay Output Voltage at Pin-7 is -15.0 ± 0.1 VDC.
 - Adjust input voltage at Pin-2 for ≤ -1.9 VDC and $\geq +1.9$ VDC.
The "IN LED" (Green) on front panel will be "illuminated".
Verify Relay Output Voltage at Pin-7 is $+15.0 \pm 0.1$ VDC.
- The ZERO or DC BIAS adjustment Pot is used to minimize errors in output voltage due to bias currents of op amps.
- A small capacitor (C1 or C8) in the pf range is placed across feedback loop to increase response time; ensure frequency stability; reduce noise gain at high frequencies; prevent oscillation at hi-freq.

TECHNICAL BACKGROUND: VARIABLE TIME DELAY

A "positive trigger pulse causes the up/down integrator output to "ramp" from "high" to "low" for a time-delay interval approximately equal to:

$$T = R \times C$$

The variable delay time is determined by adjusting Potentiometer P2 (Time-1) and Gain-1 Pot P1 for a Time Constant range of 0 to 10 Sec. The delay time is determined as follows:

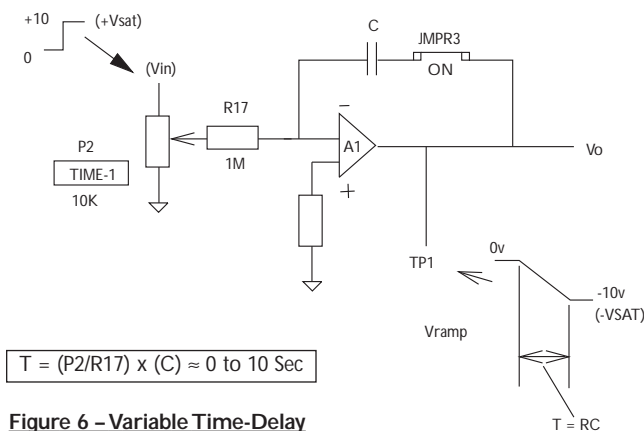

Figure 6 – Variable Time-Delay

RELAY RL1 AND RL2 SPECS

The relays are normally powered up by the incoming +24V power supply @ Pin-20 which energizes the relay and N.O./N.C. contacts for Channel-1 at Pins 7, 9 (N.C.); 7, 5 (N.O.) & 11, 13 (N.O.). The jumpers JMPR1 & JMPR4 provide capability of 'ON/OFF' options. In the 'ON' position, relays RL1 & RL2 are energized by the +24V on-board power supply and will remain energized as long as the input power supply is active. In the 'OFF' position, relays RL1 & RL2 can be externally controlled or energized by another power supply or signal switching arrangement. Generally, the 'ON' position is used since this will activate relay. Pin-11 & Pin-25 can be used for 'relay trigger'. In the 'relay trigger' mode, connect Pin-11 (Ch1) and Pin-25 (Ch2) to Power Gnd Pin-24. JMPR2 and JMPR5 must be in the 'ON' position for this to occur. JMPR2 can also be used as a relay logic jumper for changing activation state of each relay. With JMPR1 or JMPR4 in the 'ON' position (+24V) and JMPR2 or JMPR5 in the 'ON' position, the relay is in the "active-low state" (enabled-low). Grounding Pin-11 or 25 will cause relay to activate. Relay energized by a low (0VDC) logic signal may be used for integrator reset, signal switching, alarm sensing, or other functions. The N.O. contact at Pin-13 or 27 may be used for relay signal switching. With jumper JMPR2 or JMPR4 in the 'OFF' position, the N.O. contact 'b' across Pin-11, 13 (Ch1) or Pin-25, 27, may be used as an auxiliary 'dry contact' brought out for controlling an external device, alarm, etc. depending on the desired application & use.

N.O. Contact 'a' (relay RL1) across Pin-5 & 7, is an auxiliary dry contact brought out for remote control status indication. Its purpose is to provide remote indication by controlling output signal switching for such devices as an external alarm, LED warning light, or other function to monitor status condition from comparator such as HI, LO and IN led indicators provided on the front panel of the NE123-212 comparator eurocard. For example, the indicator may be used to signify whether the input voltage is above or below (fault condition) the pre-set upper and lower threshold voltage, or if it is operating within the pre-set voltage range. The contact 'a' status can also indicate power failure (+24V) or interruption.

The Output Transistor (Q1 & Q5) may be used in an optional "open" collector mode, and the relay (RL1 & RL2) may be configured for "latch/reset" operations which has adjustable Gain and Zero span.

NE123-212-1 DUAL DC LEVEL DETECTOR/COMPARATOR SCHEMATIC

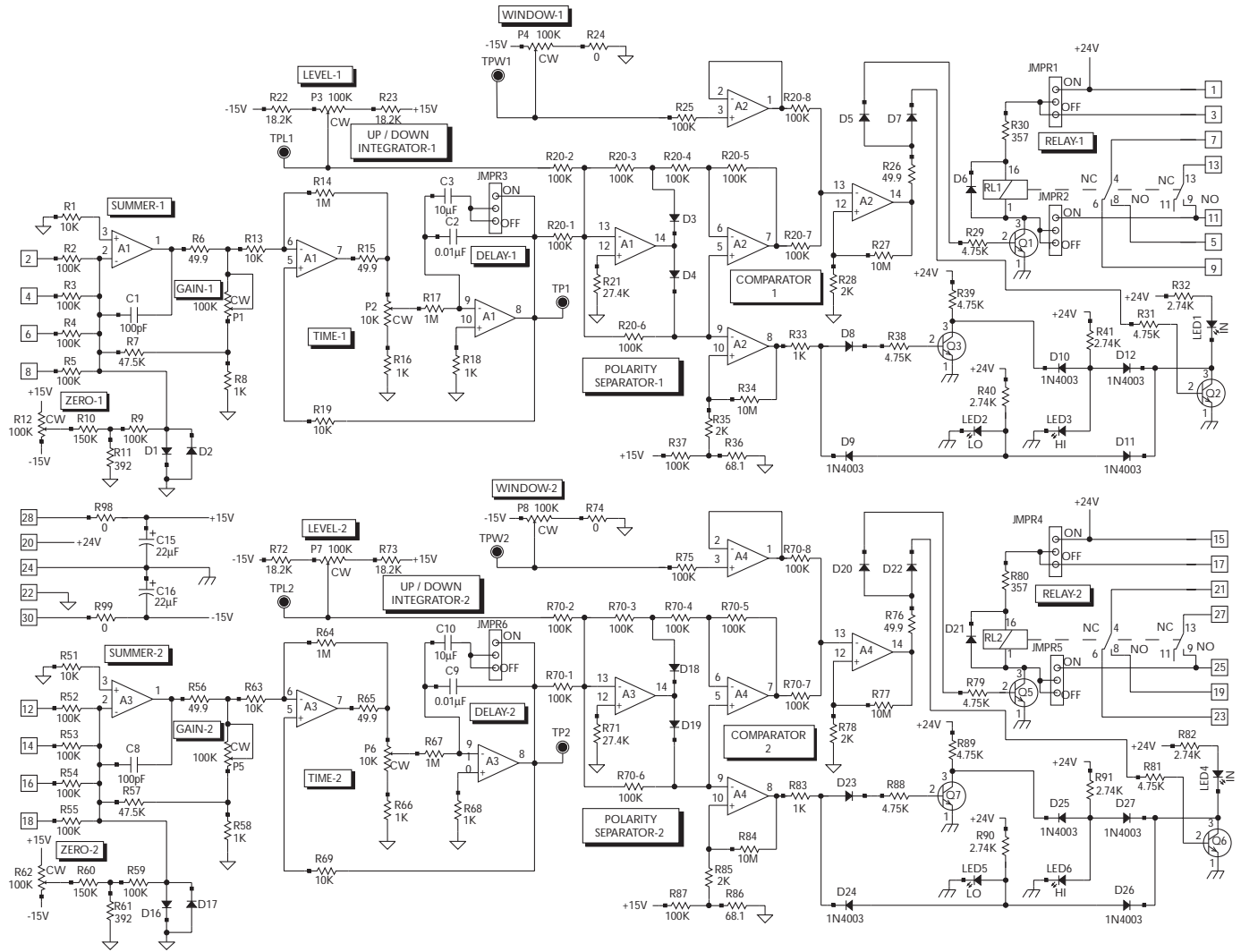

- NOTES:**
- - PIN 1 (SQUARE PAD ON PCB).
 - A1, A2, A3, A4 ARE TL084.
 - Q1, Q2, Q3, Q5, Q6, Q7 ARE 2N2222A.
 - UNLESS OTHERWISE SPECIFIED, ALL DIODES ARE 1N4148.

ADJUSTMENTS

CH1	CH2	Function
P1	P5	Gain Adjust
P2	P6	Time Adjust (Integrator Time Delay)
P3	P7	Level Adjust
P4	P8	Window Adjust
R12	R62	Zero Adjust (Offset or D-C Bias)

CH1

- JMPR1 Relay Latch/Reset Operation
- JMPR2 Output Transistor Open Collector Mode
- JMPR3 Up/Down Integrator Time Delay

CH2

- JMPR4 Relay Latch/Reset Operation
- JMPR5 Output Transistor Open Collector Mode
- JMPR6 Up/Down Integrator Time Delay

Resistor Pack	
R20/R70	Pins Used
-1	1 & 16
-2	2 & 15
-3	3 & 14
-4	4 & 13
-5	5 & 12
-6	6 & 11
-7	7 & 10
-8	8 & 9

An 'Extender Card' is highly recommended to gain access to 'Test Points' and 'Adjustments' while cards are powered-up within a Eurocard Rack Assembly. (Moog ref P/N A81750-1)

BASIC OPERATION DESCRIPTION/FUNCTIONAL DESCRIPTION

The Electronic Card Is designed to provide a variable “window” width detection circuit on each of two channels. Front Panel controls and Test Points provide “independent” setting of level and window width. Comparator status is indicated by front panel LED's. The output transistor may be used in an optional “open” collector mode, and the relay may be configured for latch/reset operation, which has adjustable Gain and Zero (Bias) span. The “summed” signal feeds an up/down integrator that provides a variable time delay. This is used to eliminate the effects of transient over signal conditions. The comparator can also be configured as a single detection circuit.

The Comparator is essentially an Analog circuit that monitors two input voltages. One voltage is called the Reference Voltage (V_{REF}) and the other is called the Input Voltage (V_{IN}). When V_{IN} “rises” above or “falls” below V_{REF} , the output of the Comparator changes states.

As an example, Channel-1 may be used to monitor voltage for one specific application such as error voltage monitoring while Channel-2 may be used to monitor a regulated power supply output. In either case, the Comparator provides the user with independent options from the same card.

FRONT PANEL INDICATORS

- There are “Six” light emitting diodes (LED's) visible on the front panel which indicate Comparator Status for various on/off switching modes
- Channel-1 and Channel-2 each have “Three” status indicator lights including the following:

Channel-1:	HI LED	LED3	RED
	LO LED	LED2	RED
	IN LED	LED1	GREEN
Channel-2:	HI LED	LED6	RED
	LO LED	LED5	RED
	IN LED	LED4	GREEN

SIGNAL FLOW DIAGRAM

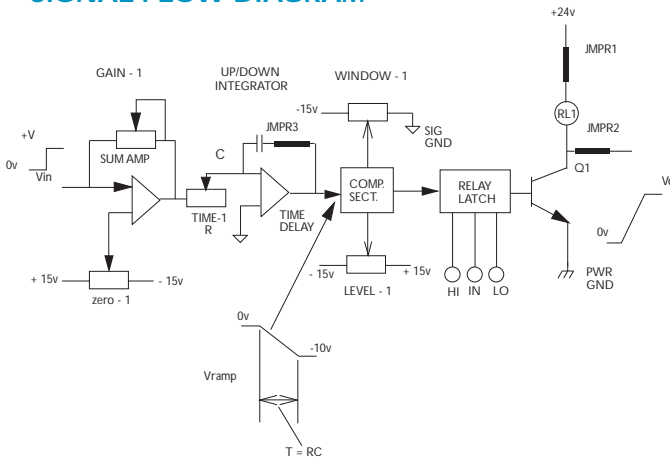

Figure 1: Channel-1: Signal Flow Diagram

- **H1 LED INDICATOR:** If the monitoring voltage should exceed the set upper limit, the HI “red” indicator light will illuminate to signify that the input voltage is above the pre-set upper threshold. The LED will go “off” when the voltage state falls to within the prescribed limits.
- **LO LED INDICATOR:** If the input voltage being monitored should drop below the pre-set lower threshold voltage, the LO “red” indicator light will illuminate. The LED will go “off” when the voltage state rises to within the prescribed limits.
- **IN LED INDICATOR:** If the input voltage being monitored operates within the pre-set lower & upper threshold voltage range, the IN “green” indicator light will remain “on”. This is the ‘NORMAL’ operating condition. The LED will go “off” should the voltage switching level “rise” above or “fall” below the prescribed limits. These conditions will illuminate a “red” LED for either fault indication.

INITIAL CUSTOMER INSTALLATION & SET-UP

Power OFF checks:

- 1) Observe all standard anti-static precautions as specified In MIL-STD-1686 Electrostatic Discharge documentation.
- 2) Carefully remove the Electronic Assembly (Comparator Card) from protective carrier at an approved static protected work station or site. A “grounded” table mat and “wrist” strap is highly recommended.
- 3) Before applying power, make a detailed visual inspection of Comparator Circuit Card.
- 4) Check Card for any damage or broken connections.
- 5) Check Assembly for any loose wiring, pinched wires or loose mechanical connections.
- 6) Verify all “six” jumpers are installed on Card. Ensure jumpers are in the proper position as specified in Adjustment Procedure Section.
- 7) With “wrist strap” connected, insert card into rack by sliding card securely in rails of rack assembly. Ensure plug is firmly seated into connector located on backplane of rack assembly.
- 8) Tighten upper & lower front panel mounting screws securely into card rack.
- 9) Install jumper wire from Pin-22 (Sig Gnd) to Pin 24 (Pwr Gnd).

Power ON checks:

- 1) Apply AC power to rack and verify all DC voltage power supply voltages are present.
- 2) Verify +15 VDC at Pin-28 & -15 VDC at Pin-30. Measurement taken with respect to Pin-22 (SIGNAL GROUND).
- 3) Verify +24 VDC at Pin-20. Measurement taken with respect to Pin-24 (POWER GROUND).
- 4) Apply +15 VDC to Pin-5 & -15 VDC to Pin-9. Monitor Relay contact output voltage at Pin-7.
- 5) Apply an input voltage of ± 3.0 VDC to Pin-2. Vary the input range.
 - a. Verify when $\text{Pin-2} \geq +2.1$ VDC. The “HI LED” (Red) is “illuminated” and Pin-7 is -15.0 VDC.
 - b. Verify when $\text{Pin-2} \leq -2.1$ VDC. The “LO LED” (Red) is “illuminated” and Pin-7 is -15.0 VDC.
 - c. Verify when $\text{Pin-2} \leq -1.9$ VDC and $\geq +1.9$ VDC. The “IN LED” (Green) is “illuminated” & Pin-7 is +15.0 VDC.

CUSTOMER ADJUSTMENT PROCEDURES: CHANNEL-1

Initial Set-up:

- 1) Set JMPR1 and JMPR2 to "ON" position.
- 2) Set JMPR3 to "OFF" position

Level and Window Comparator Setup:

- 1) Determine the desired Input Voltage Range to be monitored. The Comparator MAX WINDOW range available is ± 10.0 VDC.
- 2) Apply $+1.00 \pm 0.05$ VDC to Pin-2 (Input Monitoring Pin).
- 3) Adjust P1 (Gain-1) for -1.00 ± 0.01 VDC at TP1.
- 4) Adjust P3 (Level-1) and P4 (Window-1) to set-up desired window detection and voltage limits.
- 5) Selected setting examples include:

a. Monitoring Error Input Voltage: 0 to +10 VDC

- **Description:** This Set-up allows monitoring of an input error voltage from 0 to +10 VDC. When d-c input voltage rises above +10 VDC or falls below 0 VDC, the output changes state and LED's located on front panel will illuminate respectively. Operation within the limits will also illuminate an LED on front panel. Monitoring is performed on Channel-1.
- Adjust P3 (Level-1) for $+5.00 \pm 0.01$ VDC at TPL1
- Adjust P4 (Window-1) for 5.00 ± 0.01 VDC at TPW1
- HI LED is illuminated when Pin-2 $\geq +10.1$ VDC
- LO LED is illuminated when Pin-2 ≤ -0.05 VDC
- IN LED is illuminated when Pin-2 range is between $+0.1$ VDC and $+9.9$ VDC

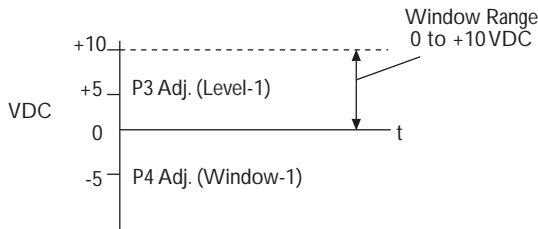

Figure 2 – Monitoring Error Input Voltage

b. Monitoring Power Supply Voltage: $+5.0 \pm 0.5$ VDC

- **Description:** This Set-up allows monitoring of regulated power supply voltage within prescribed specification limits. When d-c voltage rises above +5.5 VDC max limit or falls below 4.5 VDC min limit, the output changes state and LED's will illuminate.
- Adjust P3 (Level-1) for $+5.10 \pm 0.01$ VDC at TPL1
- Adjust P4 (Window-1) for -0.50 ± 0.01 VDC at TPW1
- HI LED is illuminated when Pin-2 $\geq +5.6$ VDC
- LO LED is illuminated when Pin-2 $\leq +4.4$ VDC
- IN LED is illuminated when Pin-2 range is between $+4.5$ VDC and $+5.5$ VDC

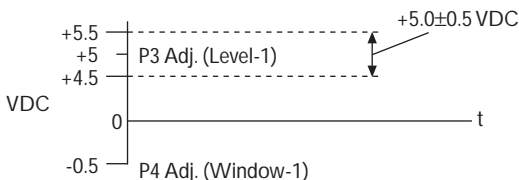

Figure 3 – Monitoring Power Supply Voltage

c. Window DC Voltage Level Detector: ± 2.0 VDC

- **Description:** This Set-up allows monitoring of on/off switching output modes that are tripped at settable levels of d-c input (+ & -). LED's on front panel are illuminated for visual indication of switching states. Typical applications include set-point detection and null-detection. Monitoring is performed on Channel-1.

- Adjust P3 (Level-1) for 0.00 ± 0.01 VDC at TPL1
- Adjust P4 (Window-1) for -2.00 ± 0.01 VDC at TPW1
- HI LED is illuminated when Pin-2 $\geq +2.1$ VDC
- LO LED is illuminated when Pin-2 ≤ -2.1 VDC
- IN LED is illuminated when Pin-2 range is between -1.9 VDC and $+1.9$ VDC
- V_{UT} is the Upper-Threshold Voltage
- V_{LT} is the Lower-Threshold Voltage

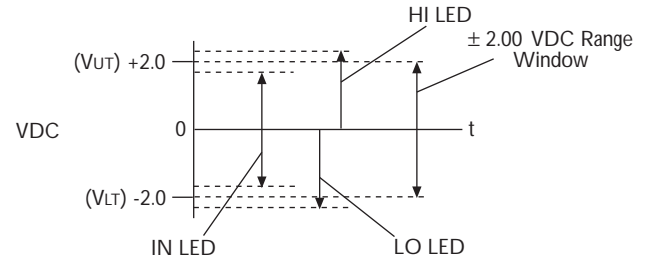

Figure 4 – Monitoring Window DC Voltage Level

TIME DELAY OPERATION & SETUP PROCEDURES: CHANNEL-1

Operation:

- 1) Set jumper "JMPR3" to "ON" position
- 2) Ensure jumper wire is installed across Pin-22 & Pin-24
- 3) Ground Pin-2 to Pin-22 (Signal Gnd)
- 4) Ensure P2 is set Fully CCW
- 5) Apply $+10.0 \pm 0.1$ VDC to Pin-2
- 6) Verify voltage at TP1 is -10.0 ± 0.5 VDC. Adjust P1 (Gain-1) if necessary to obtain desired voltage level.
- 7) Apply Oscilloscope to TP1. Vary input from 0 to +10 VDC to observe on/off switching states. Measure the "fall-time" of the negative voltage ramp as the change in states occur.
- 8) Verify the "fall-time" of the negative voltage ramp for the transition of switching level states is 90 ± 20 mSec. (See Figure 5 below)

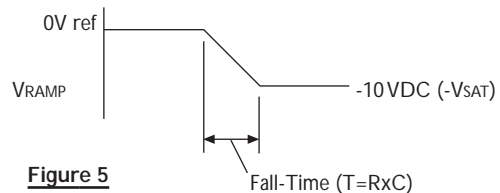

Figure 5

- 9) Set P2 Fully CW
- 10) Repeat steps (5) thru (7)
- 11) Verify the "fall-time" of the negative voltage ramp for the transition of switching level states is 900 ± 200 mSec

Set-up Procedures:

- 1) Determine required Time Delay needed for specific application.
- 2) Verify thru calculation.
- 3) Refer to chart below for Time-Delay Setting Guide:

Vin	Vo @ TP1	Gain (P1)	P2	C	JMPR3	Time-Delay
+10	-10	1	CCW	10MF	ON	0.09 Sec
+10	-10	1	CW	10MF	ON	0.90 Sec
+10	-10	10	CCW	10MF	ON	0.90 Sec
+10	-10	10	CW	10MF	ON	9.00 Sec

TROUBLESHOOTING GUIDE

General Troubleshooting

- Check interconnect wiring discontinuity caused by broken wires or loose connections
- Check circuit grounding within the interconnections or the power wiring interface
- DO NOT make electrical adjustments before checking all wiring connections, jumper locations and test point voltages
- Check power supply to ensure all voltages are present
- Monitor all Test Point positions and indicator lights before proceeding with troubleshooting checks
- Check if jumper wire is installed across signal ground and power ground
- Ensure all Power is OFF before removing or installing the Comparator Card

Symptom and Cause

- Comparator Card will NOT operate
 - AC Power to rack is not ON
 - DC power supply is not functional
 - Card plug is not fully engaged into backplane connector
 - Regulated ± 15 VDC Supply voltage is present but not Unregulated +24VDC supply to LED's and relay
- Both HI and LO LED's are illuminated
 - Jumper wire is loose or not installed across Pin-22 (Sig Gnd) and Pin-24 (Pwr Gnd)
 - Defective Potentiometer settings
 - Incorrect Power Supply hook-up to card
 - Incorrect Power Supply voltages exist
- Relay Contacts will not change on/off switching states
 - Defective Relay component
 - Incorrect jumper settings in output transistor section;
 - Set Jumpers JMPR1, JMPR2, JMPR4 & JMPR5 to ON
 - Defective output transistor (Q1 or Q2); monitor collector voltage
 - Unregulated +24VDC supply is not ON
- One or more of the LED Indicator lights will Not function
 - Defective LED component
 - Shorted Diode
 - Unregulated +24VDC Power Supply is not present
- Potentiometer adjustments on Channel-1 effect LED operation on BOTH channels
 - Jumper wire is loose or not connected across signal & power ground
 - Only one ground is connected
- Only the H1 LED or LO LED will operate
 - incorrect Level & Window Potentiometer settings
 - Shorted Diode in Relay Latching Stage
 - Power to LED is not present
- Unable to monitor desired input voltage range; HI & LO LED's will not trigger on; Only IN LED (Green) will illuminate
 - Input voltage range exceeds Maximum Window Span of ± 10 VDC
 - Window is limited to the saturation voltage of dc supply
 - Signal Ground & Power Ground are not connected
 - Power Supply Voltages are not present at LED's
- HI and LO LED's will not trigger-on at prescribed voltage limits
 - incorrect Window or Level Pot Settings
 - Adjustments performed on incorrect Channel Selection
 - Built-in Hysteresis of approximately 50mV not taken into consideration when setting up Window Limits
- Unable to set-up input voltage monitoring Window or Level
 - Incorrect Window or Level Pot Settings
 - Incorrect Adjustment procedure performed; Review Customer Set-Up procedures
 - Adjustments performed on incorrect Channel Selection
- Unable to set-up Time Delay function
 - Set jumpers JMPR3 & JMPR4 to ON position for Channel-1 & Channel-2 respectively
 - Time delay exceeds 0 to 10 Sec range; higher range may be achieved by component substitution

- Defective "TIME-1 or 2" Potentiometer
- GAIN Pot not properly adjusted
- False voltage level transitions occur along with improper LED indications
 - Signal and Power Grounds are not connected
 - Noisy input signals
 - Hysteresis too low; adjust Bias Pot (Zero)
- Excessive Output Voltage Errors and Noise occurring
 - Incorrect DC Bias Pot Adjustment
 - ZERO Pot not adjusted properly for 0VDC at TP1
 - Input Offset-Voltage driving output into Saturation
- Output Voltage resulting in Oscillation
 - Excessive input voltage Noise present resulting in Oscillation
 - Compensation Capacitor (10-1000pf) needed across current limit resistor to prevent Oscillation
 - The GAIN Adjust Pot set too High

Schematic Diagram

- NE123-212: Dual Channel Comparator/DC Level Detector
- Ref. Schematic No. G1270

GENERAL WARRANTY & SAFETY

WARRANTY CAUTION:

Disassembly, maintenance or repair other than in accordance with the instructions herein or other specific written directions from Moog Industrial Controls will invalidate MIC's obligation under its warranty. Refer to Moog Industrial Controls warranty for complete provisions thereof.

SET-UP ADJUSTMENT CAUTION:

The Comparator Card has been completely tested and adjusted including setting of the jumper positions prior to shipment from Moog-ICD. Further adjustments may be needed to achieve desired application specification requirements. Potentiometer adjustments have been provided for both Channel-1 & 2 including Gain, Time-Delay, Level Setting, Window Span and DC Bias.

All jumpers have been pre-set to the ON position except for the Time-Delay Mode which is initially set to the OFF position. If adjustments are required such as for setting up the Window or Level voltage range, refer to specific set-up and adjustment procedure instructions within this manual.

TROUBLESHOOTING NOTICE:

If a fault develops in the Comparator Card operation which was operating correctly, DO NOT make any further adjustments. The problem must be properly diagnosed by observing the LED indicator lights, checking test set-up voltages and using the troubleshooting guide as described in this manual.

DO NOT attempt to replace components or parts on the PC Circuit Board. This could cause further problems and void warranty.

WARNING!!

Use only recommended test instruments (DVM, Oscilloscope), or equivalents, when performing any diagnosis or set-up of the Comparator Card. Failure to observe this warning may result in Electronic Comparator Card damage or interfacing system modules. Refer to Set-up instruction and Adjustment Procedure sections for proper installation and operation/set-up of card.

MOOG
Industrial Controls Division
Moog Inc., East Aurora, NY 14052-0018
Telephone: 716/655-3000
Fax: 716/655-1803
Toll Free: 1-800-272-MOOG